



# Principles of Backflow Prevention

Zurn Wilkins Backflow Preventers



1.855.ONE.ZURN | ZURN.COM



# The Health and Liability Risks of Contaminated Drinking Water

Clean drinking water is something that many of us around the world take for granted. Public water supplies in the United States are generally safe and clean, but when water is contaminated, it could be deadly. From 2011 to 2012, according to the Centers for Disease Control and Prevention, in the US alone there were 32 drinking water-associated outbreaks reported, which caused at least 431 cases of illness, 102 hospitalizations, and 14 deaths<sup>1</sup>. The US Environmental Protection Agency estimates that only a small percentage of total backflow incidents are actually reported<sup>2</sup>. Contaminants infect municipal water when pipes are improperly installed or when a hose is connected to a non-potable water source. The American Backflow Prevention Association estimates more than 100,000 incidents happen every day in the United States<sup>3</sup>. Not every incident results in illness, but every incident poses a threat.

The majority of contaminated water illnesses and deaths can be prevented if issues or deficiencies within building plumbing systems and ground water systems are corrected<sup>1</sup>.

Understanding the backflow prevention terminology is the key to knowing which backflow assembly is appropriate for a given installation. Backflow prevention assemblies are life safety products. If the wrong assembly is specified, the end result can be disastrous.

## What Is Backflow?

**Backflow** is the undesirable reversal of the flow of a possible source of contamination (water or mixture of water and other liquids, gases, or other substances) into the potable water system.

## When Does Backflow Occur?

Backflow is caused by pressure changes, including conditions of gravity, vacuum, or other pressure changes. There are two factors that contribute to reversal of flow in pipelines. One is backsiphonage and the other is backpressure.

**Backsiphonage** conditions exist when there is a negative or sub-atmospheric pressure in the supply piping, allowing downstream substances to be siphoned into the potable water supply. Under-sized pipes, pipeline breaks, and high withdrawal rates can create vacuums, which contribute to the occurrence of backsiphonage.

**Backpressure** conditions exist when a pressure higher than the supply is created in the downstream piping, allowing downstream substances to be pushed into the potable water supply. Backpressure can occur when higher pressures downstream are generated by pumps, thermal expansion, and elevation.

## What is a Cross-Connection?

A **cross-connection** is any physical or potential connection, whether permanent or not, between the public potable water system and a possible source of contamination such as non-potable water, industrial fluid, gas, or other substances.

Some examples of cross-connections are fire sprinkler and irrigation systems, or hard pipe connections to equipment that uses water, such as beverage machines and dialysis equipment. Other cross-connections can be temporary, such as jumper connections, removable sections, swivel or change-over devices. An example of potential cross-connection is a hose laying next to a swimming pool — while the hose does not yet create a cross-connection, if the hose end were to be submerged into the pool, it would create a real cross-connection.

If cross-connections are not properly protected, a backflow incident could contaminate a drinking water system.

With modern drinking water systems, cross-connections are a necessity in a pressure piping system, and cannot be eliminated, therefore a means of protecting drinking water systems from contamination is essential. Zurn provides industry leading backflow prevention products for all applications.

## Assemblies vs. Devices

Mechanical backflow prevention devices and assemblies offer the best protection against cross-connection hazards.

**Backflow prevention assemblies** include an inlet and outlet shut-off valve and test cocks to facilitate testing of the assembly while it is in its functional in-line position

**Backflow prevention devices** prevent backflow by stopping the reversal of flow, and are not testable once installed because they do not have inlet and outlet shut-off valves or test cocks

## Containment and Isolation

An effective cross-connection control program will include requirements for both premise containment (meter or service protection) and isolation (internal protection).

**Service protection** is installed on a water connection at the point where the water purveyor transfers control of the water to the consumer's water system.

**Internal protection** is installed in the consumer's potable water system at the point of use of the water.

## Standards, Approvals, and Listings

Approval agencies, representing many diverse geographical areas and levels of government, have established performance criteria regarding the function, manufacturing, installation, testing and maintenance of backflow prevention devices and assemblies.

The overall objective of the performance criteria is to establish a baseline to ensure the sanctity of drinking water; however, each standard specifies different requirements relating to mechanical function, material requirements and testing for backflow preventers.



350 Double Check Valve Assembly installed to protect against backsiphonage and backpressure in low hazard applications

# Selecting a Backflow Preventer

Zurn provides numerous types of backflow preventers to meet industry standards, which are set to provide the right level of protection depending on system conditions.

## What type of backflow preventer should be used?

Backflow prevention devices and assemblies include:

- Atmospheric Vacuum Breakers
- Dual Check Valves
- Pressure Vacuum Breakers
- Double Check Valve Assemblies
- Reduced Pressure Principle Backflow Assemblies

The proper selection of a backflow preventer is crucial to ensure that it works properly and provides adequate protection for the specific application. Not all backflow preventers provide the same level of protection and the following must be taken into consideration when defining the proper product for an application.

## System Characteristics

Each backflow preventer is designed to handle a specific group of system characteristics. System characteristics include the hydraulic requirements of the specific backflow prevention design, such as:

### Backpressure versus backsiphonage

#### Continuous pressure versus non-continuous pressure

- Non-continuous pressure cannot be applied for more than 12 hours continuously during a 24 hour time period

#### Existing conditions of pressure loss

- Pressure loss within a plumbing system occurs from pipe, fittings, and valves
- Backflow preventers, which utilize check valves, contribute to pressure loss
- Flow curves provide pressure loss data on backflow preventers

#### Elevation in the piping system

- The weight of water in a column contributes approximately 1 psi for every 28 inches of column height, so the pressure at the bottom of the column is greater than the pressure at the top
- A 10 story building can lose almost 35 psi in water pressure from the ground floor to the top floor

## Degree Of Hazard

Should a backflow condition occur, the degree of hazard must be understood in order to provide the proper backflow preventer. The degree of hazard is the primary factor when determining the proper product.

**Low hazard** application: potential backflow can pollute the drinking water

- **Pollution** is defined as materials that can cause undesirable effects to the water, such as discoloration, smell or taste, but will not cause sickness or death

**High hazard** application: potential backflow can contaminate the water supply

- **Contamination** is defined as any impairment to the water quality such that contact with this water can result in illness or death

A **lethal hazard** involves radioactive material or raw sewage. An air gap is the only effective means of protecting against lethal hazards. Under no circumstance would a mechanical backflow preventer be used to protect against a lethal hazard.

## Type of Application

The **type of application** and industry, such as fire protection, irrigation, waterworks, and plumbing, each have particular requirements. Fire sprinkler systems may require detector assemblies, and irrigation systems may require products that are not used universally in plumbing systems.

Each application is also unique in regards to flow requirements. Plumbing and waterworks require consistent flow of water. Irrigation requires flow perhaps 2% of the time and the remaining 98% of the time is in a static condition. Fire protection must stand ready for action with 100% static water pressure. Each application can present a unique situation, which will affect a backflow preventer differently.



375XL Reduced Pressure Principle Assemblies installed in a commercial shopping center

## Type of Installation

**Installation types** include outdoor, indoor, below grade (pit installations), horizontal, and vertical installations.

Facilities that require uninterrupted supply of water, such as hospitals, resort hotels, or industrial applications, will require multiple connections or manifold assemblies.

- Outdoor installations face the potential of vandalism, theft, soil erosion, and freezing temperatures. Protective enclosures can help to mitigate some of these issues.
- Indoor installations might need to address the issue of water discharge. Of the five standard types of backflow preventers, three spill water, two at start-up and one as a normal function.
- Below grade installations can be convenient, but are limited to certain types of backflow preventers. Care must be taken to provide accessibility for testing and maintenance.
- Horizontal installations are the most common.
- Vertical installations are limited to certain types of backflow preventers. Reduced Pressure Principle Backflow Preventers may not be suitable for vertical installations. Understanding the direction of flow (flow-up or flow-down) is important from an approval standpoint.

Accessibility is required for testing, maintenance or repair, yet is often overlooked. Height requirements are defined by industry standards.

## Testable Backflow Prevention Assemblies vs. Non-Testable Backflow Devices

The local authority having jurisdiction will ultimately determine whether a testable backflow prevention assembly or non-testable backflow device is used.

Typically, **testable backflow prevention assemblies** are required for use at a service connection, but may also be used for internal protection. Since their proper function is imperative in order to prevent contamination of the public potable water supply, a method of testing is necessary.

**Non-testable backflow devices** are usually used for internal protection, within the consumer's potable system. If these types of valves fail, protection of the public potable supply is still facilitated by the testable assembly installed at the service connection.

## Lead-Free Law Compliance

On January 4, 2014, changes to the Safe Drinking Water Act went into effect which mandate that all commercial plumbing fixtures, valves, pipes, and fittings that are directly intended for human water consumption are required to be manufactured with less than .25% leaded brass content.

Exceptions exist for product used in non-potable applications such as fire protection and irrigation. For more information on the Safe Drinking Water Act and lead-free initiative, please visit [zurn.com/innovation-efficiency/lead-free](http://zurn.com/innovation-efficiency/lead-free).

# Determining Which Type of Backflow Preventer to Use

## Selection Guide for All Zurn Wilkins Backflow Assemblies

MODEL	TYPE	APPLICATION					EXAMPLES OF INSTALLATION
		BACKSIPHONAGE	BACKPRESSURE	CONTINUOUS PRESSURE	LOW HAZARD	HIGH HAZARD	
375XL/375 375AST/375A/375 475 975	Reduced Pressure Principle	✓	✓	✓	✓	✓	Irrigation, Plumbing, Waterworks, Industrial, Medical, Fire Sprinkler
975XL 975XLV 975XLSE		✓	✓	✓	✓	✓	
975BMS/MS 975XLBMS/MS FCIS	Reduced Pressure Principle with Integral Monitor Switch	✓	✓	✓	✓	✓	Indoor applications where undetected discharge could cause water damage
375ASTDA/375DA 375ASTDA/375ADA 475DA 975DA	Reduced Pressure Principle Detector Assembly	✓	✓	✓	✓	✓	Fire Sprinkler System Supply Main. Detects Leaks and Unauthorized Use of Water
350XL/350 350AST/350A/350 450	Double Check Assembly	✓	✓	✓	✓		Irrigation, Plumbing, Waterworks, Industrial, Medical, Fire Sprinkler
950XL 950XLT 950XLV		✓	✓	✓	✓		
350ASTDA/350DA 350ADA 450DA 950XLTDA(BF)	Double Check Detector Assembly	✓	✓	✓	✓		Fire Sprinkler, System Supply Main. Detects Leaks and Unauthorized Use of Water
700XL 700XLFP 705	Dual Check	✓	✓	✓	✓		Residential Supply Lines and Fire Sprinkler Systems
760	Dual Check with Atmospheric Vent	✓	✓	✓	✓		Boiler Feed Lines, Laboratory Equipment, Residential
40XL2	In-Line Spring-Loaded Check Valve	✓	✓	✓	✓		Irrigation, Pump and Water Hammer Applications
310	Single Check	✓	✓	✓	✓		
310DA	Single Check Detector Assembly	✓	✓	✓	✓		Fire Sprinkler System Supply Main. Detects Leaks and Unauthorized Use of Water
420XL 460XL 720A	Pressure Vacuum Breaker	✓		✓	✓	✓	Irrigation and Lawn Sprinkler Systems
35XL	Atmospheric Vacuum Breaker	✓			✓	✓	Laboratory Sinks, Lawn Sprinklers, Commercial Laundry
BFP-8F BFP-9	Hose Connection Vacuum Breaker	✓			✓		Hose Bibbs, Service Sinks, Hydrants

# Types of Backflow Preventers

## Atmospheric Vacuum Breaker (AVB)

An **AVB** is a device containing a float-check, a check seat, and an air inlet port. The flow of water into the body causes the float to rise and close the air inlet port. When the flow of water stops, the float falls and forms a check valve against backsiphonage and, at the same time, opens the air inlet port to allow air to enter and satisfy the vacuum. A shut-off valve immediately upstream may be an integral component of the assembly.

### SYSTEM CHARACTERISTICS

- Non-continuous pressure application (no more than 12 hours of pressure per 24 hour period)
- Backsiphonage condition only
- Provides protection in low and high hazard situations

### TESTING

This device is not testable once installed.

### HEIGHT REQUIREMENT

Installed 6" above the highest point in the water system downstream.



35XL

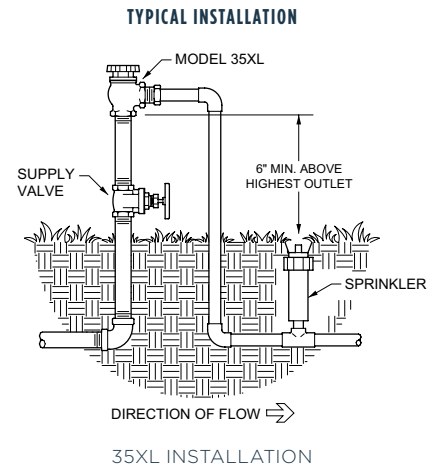

## Pressure Vacuum Breaker (PVB)

A **PVB** is an assembly containing an independently acting, internally loaded check valve with an independently acting loaded air inlet valve, located on the discharge side of the check valve. A PVB shall have two resilient-seated isolation valves attached at each end of the assembly and two properly located resilient seated test cocks.

### SYSTEM CHARACTERISTICS

- Continuous and non-continuous pressure applications
- Backsiphonage condition only
- Provides protection in low and high hazard situations

### TESTING

- The air inlet valve shall open when the pressure in the body is no less than 1.0 psi above atmospheric pressure. And, the air-opening valve shall be fully open when the water drains from the body.
- The check valve shall be drip tight in the normal direction of flow when the inlet pressure is 1 psi and the outlet pressure is atmospheric.

### HEIGHT REQUIREMENT

Installed 12" above the highest point in the water system downstream with adequate clearance for testing and maintenance.



720A

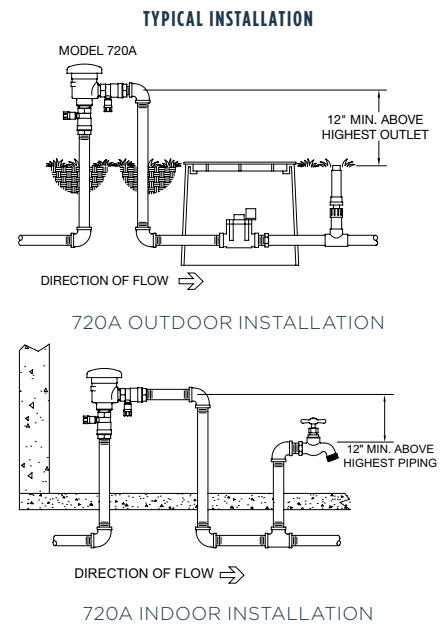

460XL

## Spill Resistant Vacuum Breaker (SVB)

A **SVB** is the same as a Pressure Vacuum Breaker except that the Spill Resistant Vacuum Breaker is less prone to discharge upon fill, and is recommended for indoor installations.

During start-up and operation, a separate diaphragm seals the air inlet from the water supply preventing spillage. The assembly is designed for use under constant pressure and provides protection where a potential health hazard exists.

## Dual Check Valve and Dual Check with Atmospheric Port

**Dual Checks** are designed for use in low hazard applications where a fully approved, testable backflow preventer is not required. Check with the local authority having jurisdiction for acceptance.



700XL

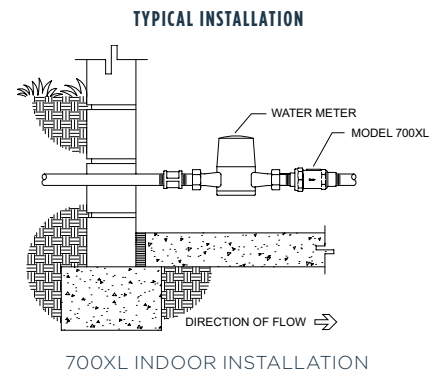

## Double Check Valve Assembly (DC)

A **DC** is an assembly containing two independently acting approved check valves, four resilient-seated test cocks, and two resilient-seated isolation valves.

### SYSTEM CHARACTERISTICS

Continuous and non-continuous pressure applications  
 Backsiphonage and backpressure conditions  
 Provides protection in low hazard situations

### TESTING

- 1 The No. 1 check valve shall be tight against reverse flow under all pressure differentials. The static differential pressure across the No. 1 check valve must be at least 1 psid.
- 2 The No. 2 check valve shall be tight against reverse flow under all pressure differentials. The static differential pressure across the No. 2 check valve must be at least 1 psid.

### HEIGHT REQUIREMENT

Installed between 12"-30" above the floor or finished grade with adequate clearance for testing and maintenance. If installation is in a pit or vault, provide ample drainage to ensure the backflow preventer does not become submerged.

Side clearance requirement from the wall of Double Check and Reduced Pressure Principle Assemblies (1/2"-3") are 24" from side test cocks, 12" from top mounted test cocks, with 24" access from one side. For sizes 4" and above, these requirements are doubled. The weight of the checks must also be considered, especially if you are looking at a vertical installation. The check assembly weight for an 8"-10" device may require lifting assistance.



350XL



350AST

### TYPICAL INSTALLATION

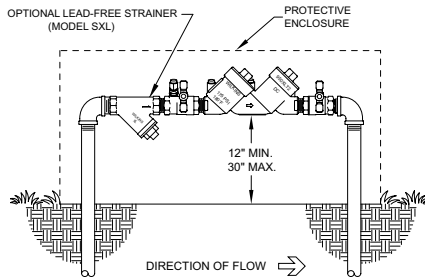

950XLT OUTDOOR INSTALLATION

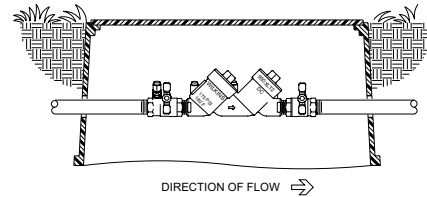

950XLT PIT INSTALLATION

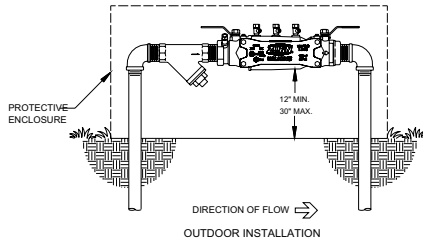

350XL OUTDOOR INSTALLATION

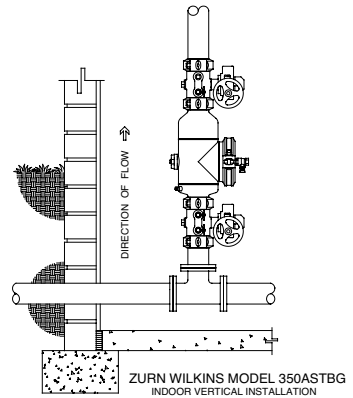

350ASTBG INDOOR INSTALLATION

## Double Check Detector Assembly (DCDA)

A **DCDA** is a specially designed assembly composed of a line-sized approved double check valve assembly, with a specific by-pass water meter, and a meter-sized approved double check valve assembly. The meter shall register accurately for all flows up to and including two gpm.

### SYSTEM CHARACTERISTICS

Continuous and non-continuous pressure applications  
 Backsiphonage and backpressure condition  
 Provides protection in low hazard situations only

### TESTING

- 1 The static differential pressure across the No. 1 check valve must be at least 1 psid.
- 2 The static differential pressure across the No. 2 check valve must be at least 1 psid.

### HEIGHT REQUIREMENT

Installed between 12"-30" above the floor or finished grade with adequate clearance for testing and maintenance. If installation is in a pit or vault, provide ample drainage to ensure the backflow preventer does not become submerged.

Side clearance requirement from the wall of Double Check and Reduced Pressure Principle Assemblies (1/2"-3") are 24" from side test cocks, 12" from top mounted test cocks, with 24" access from one side. For sizes 4" and above, these requirements are doubled. The weight of the checks must also be considered, especially if you are looking at a vertical installation. The check assembly weight for an 8"-10" device may require lifting assistance.



350ASTDABF

### TYPICAL INSTALLATION

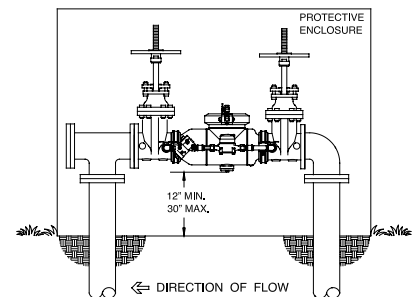

350ASTDAOSY OUTDOOR INSTALLATION

## Reduced Pressure Principle Assembly (RP)

A **RP** is an assembly containing two independently acting approved check valves together with a hydraulically operated, mechanically independent differential pressure relief valve located between the two check valves.

### SYSTEM CHARACTERISTICS

Continuous and non-continuous pressure applications  
 Backsiphonage and backpressure conditions  
 Provides protection in low and high hazard situations

### TESTING

- 1 The pressure differential relief valve must operate to maintain the "zone" between the two check valves at least 2 psi less than the supply pressure.

- 2 The No. 2 check valve shall be tight against reverse flow under all pressure differentials.
- 3 The static pressure drop across check valve No. 1 shall be greater than the relief valve opening point (test no. 1), and at least 5.0 psid.

### HEIGHT REQUIREMENT

Installed between 12"-30" above the floor or finished grade with adequate clearance for testing and maintenance.

Side clearance requirement from the wall of Double Check and Reduced Pressure Principle Assemblies (1/2"-3") are 24" from side test cocks, 12" from top mounted test cocks, with 24" access from one side. For sizes 4" and above, these requirements are doubled. The weight of the checks must also be considered, especially if you are looking at a vertical installation. The check assembly weight for an 8"-10" device may require lifting assistance.



375XL



375AST

### TYPICAL INSTALLATION

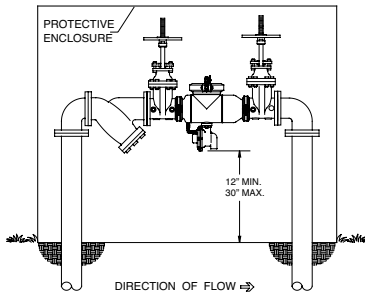

375ASTOSY OUTDOOR INSTALLATION

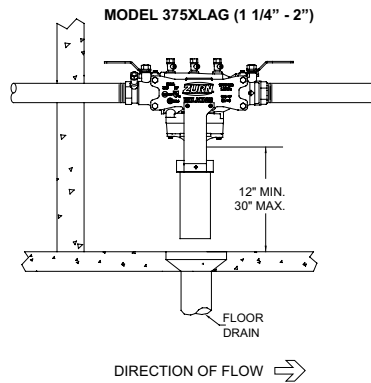

375XL INDOOR INSTALLATION

## Reduced Pressure Principle Detector Assembly (RPDA)

A **RPDA** is a specially designed assembly composed of a line-sized approved reduced pressure principle backflow assembly, with a specific by-pass water meter and a meter-sized approved reduced pressure principle backflow prevention assembly. The meter shall register accurately for all flows up to and including two gpm. The meter shall show a registration for all flows above two gpm.

### SYSTEM CHARACTERISTICS

Continuous and non-continuous pressure installations  
 Backsiphonage and backpressure conditions  
 Provides protection in low and high hazard situations

### TESTING

- 1 The pressure differential relief valve must operate to maintain the "zone" between the two check valves at least 2 psi less than the supply pressure.

- 2 The No. 2 check valve shall be tight against reverse flow under all pressure differentials.
- 3 The static pressure drop across check valve No. 1 shall be greater than the relief valve opening point (test no. 1), and at least 5.0 psid.

### HEIGHT REQUIREMENT

Installed between 12"-30" above the floor or finished grade with adequate clearance for testing and maintenance.

Side clearance requirement from the wall of Double Check and Reduced Pressure Principle Assemblies (1/2"-3") are 24" from side test cocks, 12" from top mounted test cocks, with 24" access from one side. For sizes 4" and above, these requirements are doubled. The weight of the checks must also be considered, especially if you are looking at a vertical installation. The check assembly weight for an 8"-10" device may require lifting assistance.



375ASTDABG

### TYPICAL INSTALLATION

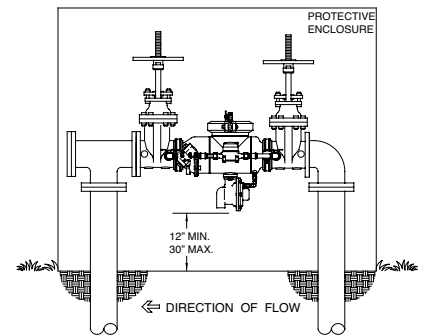

375ASTDA OUTDOOR INSTALLATION



# Operating Principles of the Zurn Wilkins Model 975XL Reduced Pressure Principal Backflow Preventer

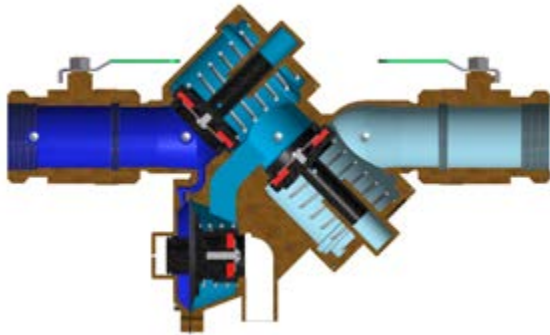

## Static (No Flow) Condition

Both check valves are closed in a static (no flow) condition. Pressure on the supply side of the valve is approximately 8 psi higher than the pressure in the reduced pressure zone, therefore the relief valve is held in a closed position.

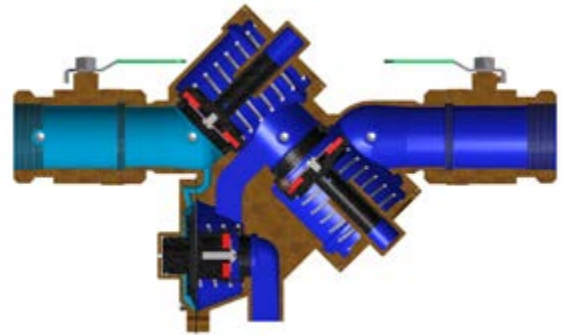

## Backpressure with 2nd Check Fouled

Potentially contaminated liquid will flow into the reduced pressure zone of the valve. As the zone pressure increases to within 2 psi of the inlet pressure, the relief valve begins to open and discharges to the atmosphere.

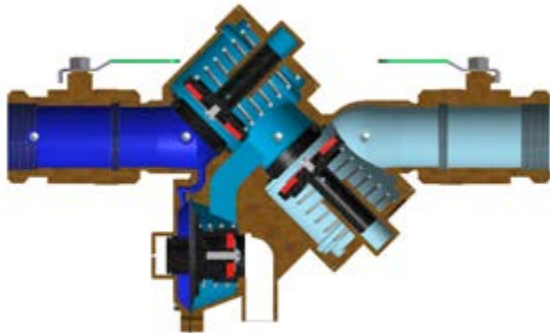

## Normal Flow

Both check valves are open in a normal flow condition. The relief valve is held in a closed position because of the higher pressure on the supply side of the valve. Pressure in the reduced pressure zone is approximately 8 psi lower than the supply side of the valve.

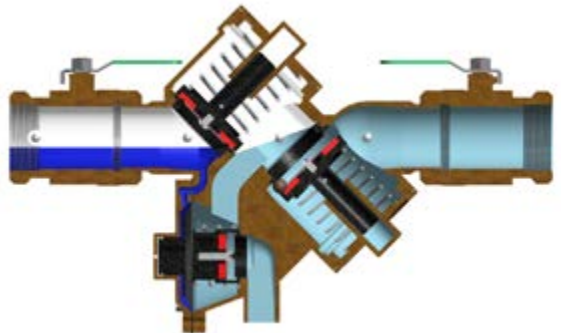

## Backsiphonage with 2nd Check Fouled

The inlet pressure becomes negative or subatmospheric. Because the pressure on the supply side is lower than the zone pressure, the relief valve goes to a full open position and discharges to the atmosphere.

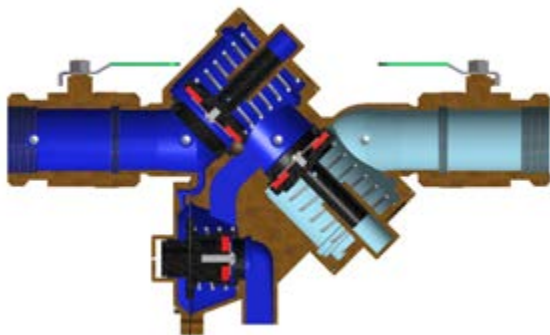

## Static Condition with 1st Check Fouled

Fluid will leak from the inlet into the reduced pressure zone. As the zone pressure increases to within 2 psi of the inlet pressure, the relief valve begins to open and discharges to the atmosphere. The amount of fluid discharging from the relief valve is proportional to the extent of the foul across the 1st check.

### KEY:

- Inlet pressure
- Zone pressure
- Outlet pressure
- Atmospheric pressure

DIRECTION OF FLOW

# Reduced Pressure Backflow Assembly Troubleshooting Guide

Below is a simple troubleshooting method that does not require a test kit to identify the root causes for relief valve discharge.

## After observing water discharge from relief valve port:

- 1 Close #2 shut off valve.  
If discharge stops, the problem is a fouled second check while under backpressure.
- 2 If discharge continues, open #4 test cock.  
If discharge stops or is reduced, the problem is a fouled first check.
- 3 If discharge continues, the problem is most likely in the relief valve.

## Solution

Disassemble and clean affected components and remove debris from the backflow preventer.

If you are still experiencing issues after completing these initial troubleshooting steps, contact our OneZurn Customer Care department for further assistance.

## REFERENCES

<sup>1</sup> Centers for Disease Control and Prevention (August 14, 2015). Surveillance for Waterborne Disease Outbreaks Associated with Drinking Water — United States, 2011–2012 (64(31);842-848). Retrieved from <http://www.cdc.gov/mmwr/preview/mmwrhtml/mm6431a2.htm>

<sup>2</sup> Environmental Protection Agency (September 27, 2001). Potential Contamination Due to Cross-Connections and Backflow and the Associated Health Risks. Retrieved from [https://www.epa.gov/sites/production/files/2015-09/documents/2007\\_05\\_18\\_disinfection\\_tcr\\_issuepaper\\_tcr\\_crossconnection-backflow.pdf](https://www.epa.gov/sites/production/files/2015-09/documents/2007_05_18_disinfection_tcr_issuepaper_tcr_crossconnection-backflow.pdf)

<sup>3</sup> ABPA cited in: A.M. Petrillo, 'Backflow Basics', Reeves Journal. March 2006. pp.50-2.

# How to Read Performance Curves

The flow characteristics of a backflow preventer is defined by a "Performance Curve," depicting the relationship of pressure drop and flow rate throughout its full range of operation. The full range of operation is referred to as the "usable range." Flow rates beyond the usable range will have velocities destructive to the piping system or excessive pressure loss. The basis for flow capacity and pressure loss in a backflow prevention assembly begins at zero gpm and goes up to the industry standard, American Water Works Association (AWWA) required maximum flow capacity. This maximum rate is known as "rated flow." For any flow rate from zero gpm up to the rated flow, there is an established maximum allowable pressure loss. Failure to meet the required flow rates or exceeding the maximum pressure drop at any point up to the rated flow would prevent the assembly from being approved.

All Zurn Wilkins Backflow Prevention Assembly performance curves are constructed with the "flow rate" in gallons per minute (gpm) or liters per second (l/s) on the horizontal axis and the "pressure loss" in pounds per square inch (psi) or kilopascals (kpa) on the vertical axis. Additionally, a diamond will be placed on the curve to indicate the maximum rated flow for each given assembly, according to its pipe size.

## Example

Find the pressure loss exhibited by a 4" 350A Reduced Pressure Principle Backflow Prevention Assembly while the valve is flowing at 400 gpm (see chart below).

## Solution

Follow the horizontal axis out to 400 gpm. Next, move upward until the 400 gpm axis intersects the 4" 350A curve. At this juncture, moving to the left, read the pressure loss from the vertical axis that corresponds with the intersection of the 400 gpm axis and the 4" 350A curve. The pressure loss at 400 gpm is taken to be 3.5 psi. Also, from the curve, we see that the diamond is at the value of 500 gpm. Therefore, the maximum rated flow of a 4" Zurn Wilkins 350A is 500 gpm.

Note: To properly interpret the following Zurn Wilkins backflow performance curves, the flow rates on the top are indicated in "liters per second" and the bottom flow rates are in "gallons per minute."

## EXAMPLE FLOW CURVES

**MODEL 350A 2 1/2", 3" & 4" (STANDARD & METRIC)**

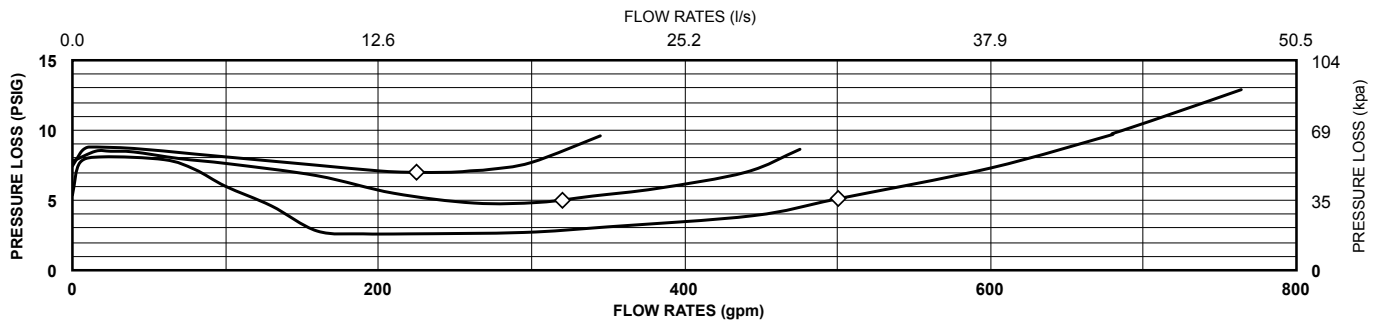

**MODEL 350A 6", 8" & 10" (STANDARD & METRIC)**

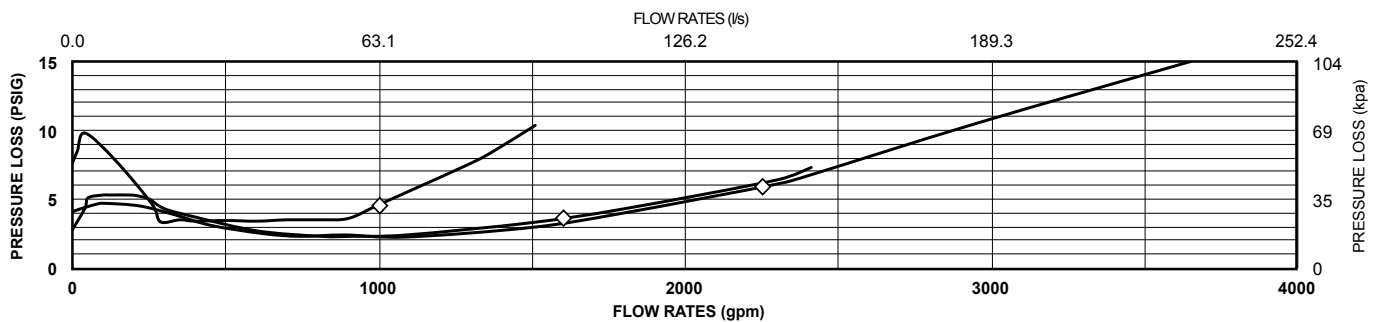

Zurn Engineered Water Solutions® is a recognized leader in commercial, municipal, and industrial markets, delivering sustainable building solutions for new construction and retrofit applications. At Zurn we are committed to providing smart solutions that save both time and money. Our goal is serving the customer through innovation, continuous improvement, and assurance behind every installation. Choose Zurn for a reliable, recognized manufacturer to supply your entire installation, from behind the wall rough-in, to finish trim product and fixture systems.



**Zurn Wilkins**  
1747 Commerce Way  
Paso Robles, CA 93446, 855-663-9876

In Canada  
**Zurn Industries Limited**  
7900 Goreway Drive, Unit 10  
Brampton, Ontario L6T 5W6, 905-405-8272

1.855.ONE.ZURN | [ZURN.COM](http://ZURN.COM)

Form No. ZMKTG480-27, Rev. 11/16